

Revision Notes.				
R1 -				
APA: -	Drawn:-	Checked:-	Approved:-	Date: -

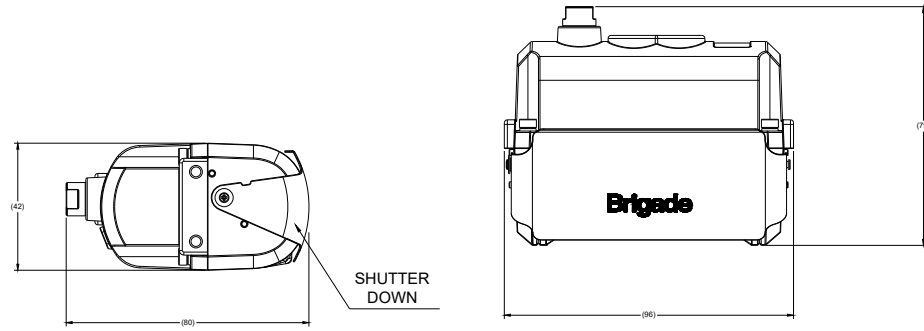
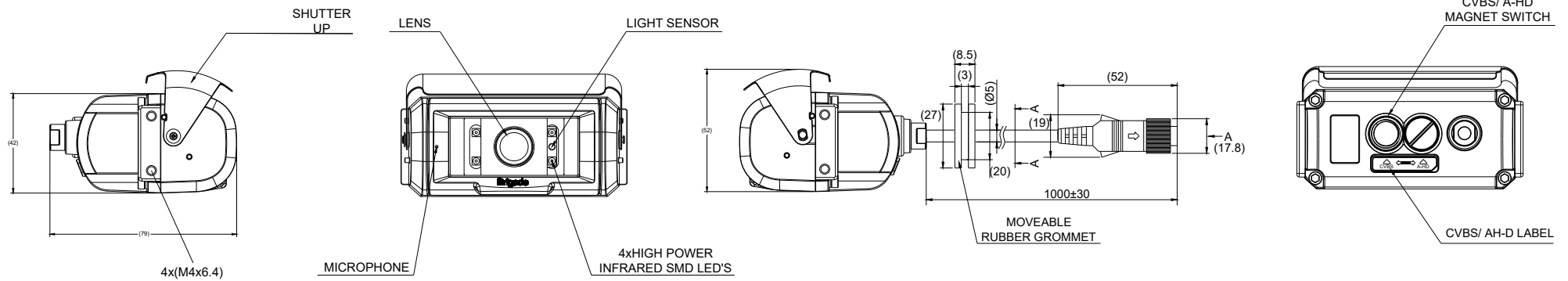

TABLE 1: BE-811XC-C CAMERA ONLY OPTIONS

PART NO.	MODEL NO.	DESCRIPTION
8174	BE-8110C-C	ELITE SHUTTER CAMERA, HEATED & AUDIO CVBS/AHD 1080P (PAL/25FPS) - CAMERA ONLY
8175	BE-8111C-C	ELITE SHUTTER CAMERA, HEATED & AUDIO CVBS/AHD 1080P (NTSC/30FPS) - CAMERA ONLY



VIEW A

VIEW A-A

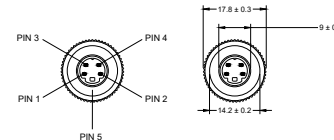

4 PIN MINI DIN MALE MATING FACE

PIN #	WIRE COLOUR	DESCRIPTION
1	YELLOW	VIDEO
2	RED	+12V
3	BLUE	ADDITIONAL FUNCTION SHUTTER (CONTROL)
4	WHITE	AUDIO
5	SHIELD	GND

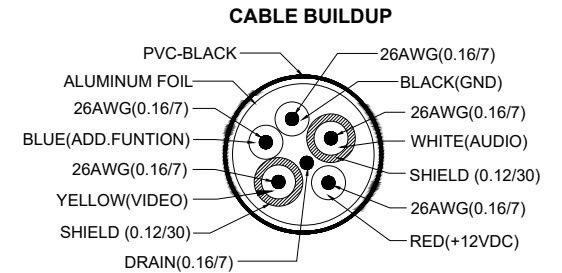

NOTES:

- REFER TO PRODUCT SPECIFICATION FOR PRODUCT SPECIFICATIONS.
- FOR LABEL AND PACKAGING DETAILS REFER TO MASTER BOM.
- FIRMWARE TO BE INSTALLED FROM FACTORY FOR THE BE-8110C: MG_B23DPS-XXX_REV1.3(250912)
- FIRMWARE TO BE INSTALLED FROM FACTORY FOR THE BE-8111C: MG_B23DNS-XXX_REV1.3(250912)
- ANY CUSTOMER MODIFICATION OF THIS PRODUCT CAUSING SUBSEQUENT FAILURE IS NOT A LIABILITY OF BRIGADE ELECTRONICS PLC.

PROPRIETARY NOTICE
THIS DESIGN AND TECHNICAL INFORMATION APPEARING ON THIS DRAWING IS THE PROPERTY OF BRIGADE ELECTRONICS, AND IS DISCLOSED IN CONFIDENCE. IT IS NOT TO BE COPIED, REPRODUCED, REVEALED TO OR EXPROPRIATED BY OTHERS, EITHER IN WHOLE OR IN PART WITHOUT THE EXPRESS WRITTEN CONSENT OF BRIGADE ELECTRONICS.

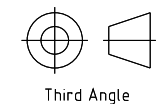

Sheet 1 of 1	Assembly Pt Approval T. CHOI	Approved by A. KEBEDE	Checked by F. ADEMUJIMI	Drawn by E. MATHEW
Customer Approval N/A	Angle of Projection	Units mm	Scale N/A	Released 13/10/2025
		Status RELEASED	BE-811XC-C	
		Part No SEE TABLE 1	BE-004983-00-24	